



<https://cloudblue.com>

[Documentation](#)  [Modules](#)  [Streams](#) 

# Key Concepts & Terminology



This article has been generated from the online version of the documentation and might be out of date. Please, make sure to always refer to the online version of the documentation for the up-to-date information.

Auto-generated at April 16, 2025

Understanding keys concepts and associated terminology is necessary to use all advantages of the Commerce module and also to streamline required business operations in your organization. The following article introduces essential concepts and describes key workflows around the data streams, billing and pricing functionality on the Connect platform.

## Data Stream Management

The core functionality the *Data Stream Management* is a process of transferring table-based data from Vendors through the supply chain. Therefore, this process allows establishing continuous commercial interactions between organizations and implementing business scenarios that are illustrated and described below:

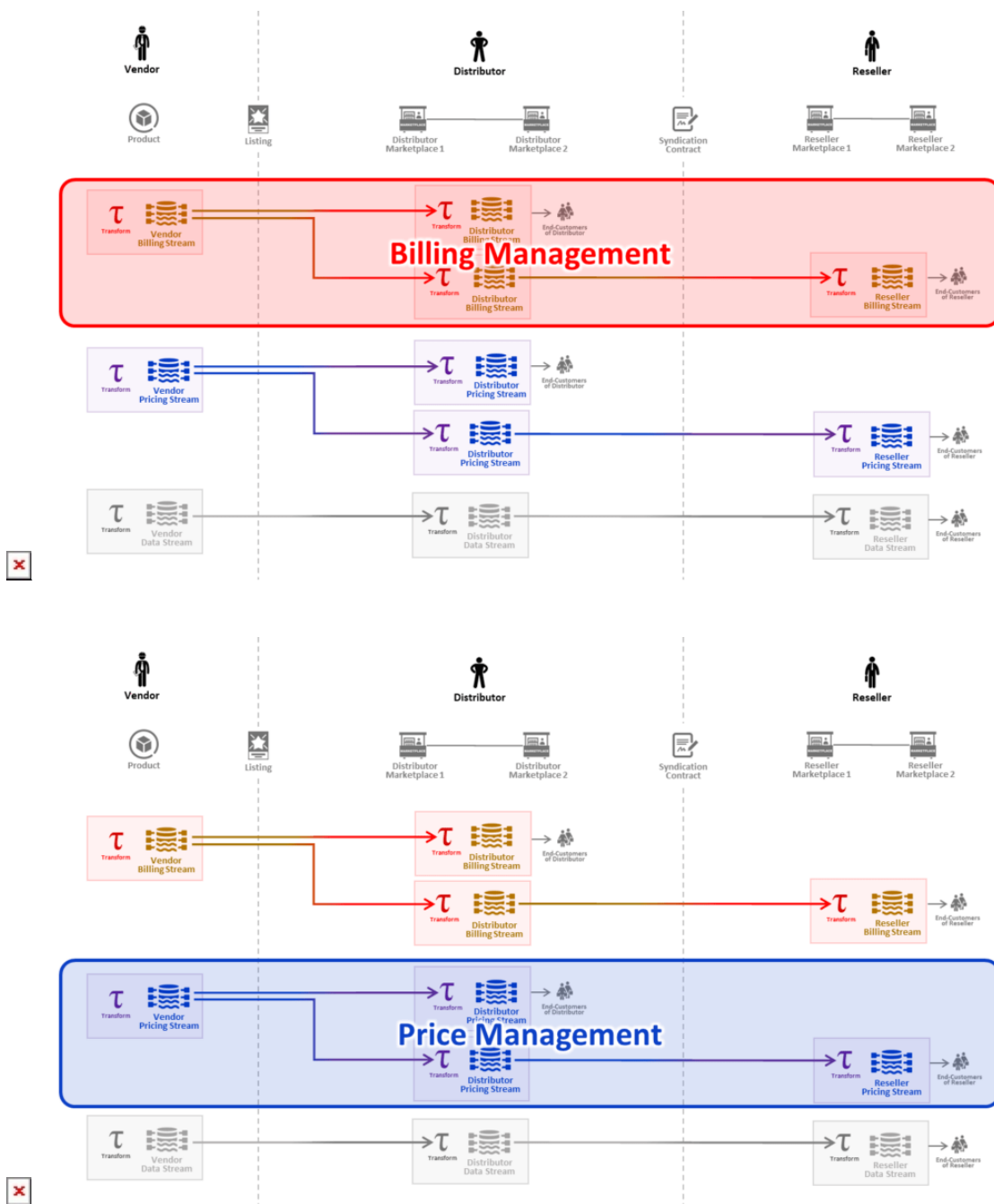

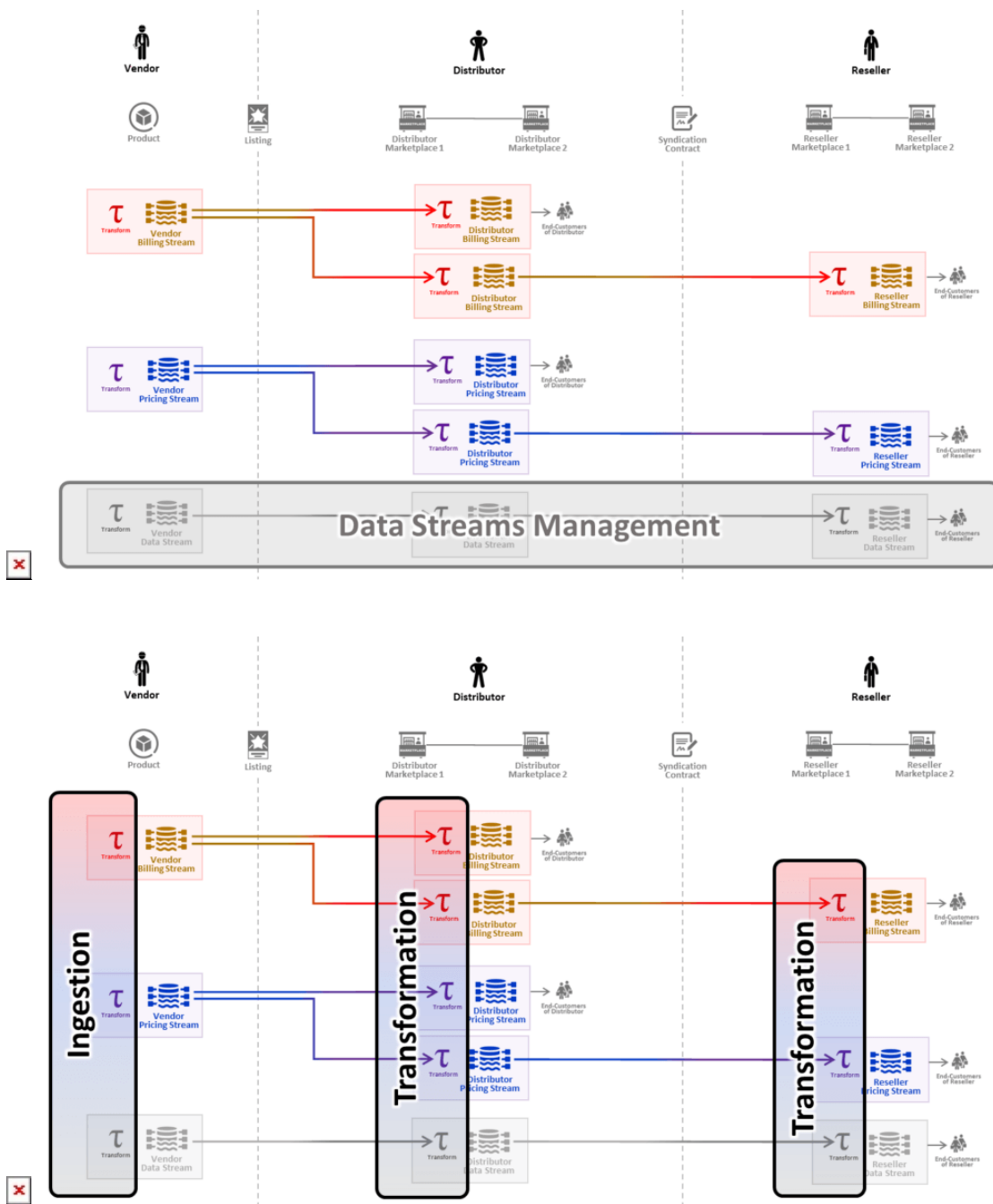

- **Billing Management:** Organizes processes of transferring *billing data* from Vendors through the supply chain layers with optional transformation on the way.
- **Price Management:** Governs processes of transferring *pricing data* (also called *price lists*) within the supply chain layers with optional transformation on the way.
- Other business scenarios, such as *cost estimates*, *inventory*, and more.

Data stream management also incorporates **data transformation** that represents a process of modifying information in billing streams, pricing streams, and other data streams. Depending on your data and operation, data transformation may represent



**rating, conversions, lookups, data enrichment**, or other specific scenarios. Initial data transformation performed by Vendors is often called *ingestion* on the Connect platform.

The following illustrates the direction of data transformations and describes typical billing data transition from one organization to another as an example:

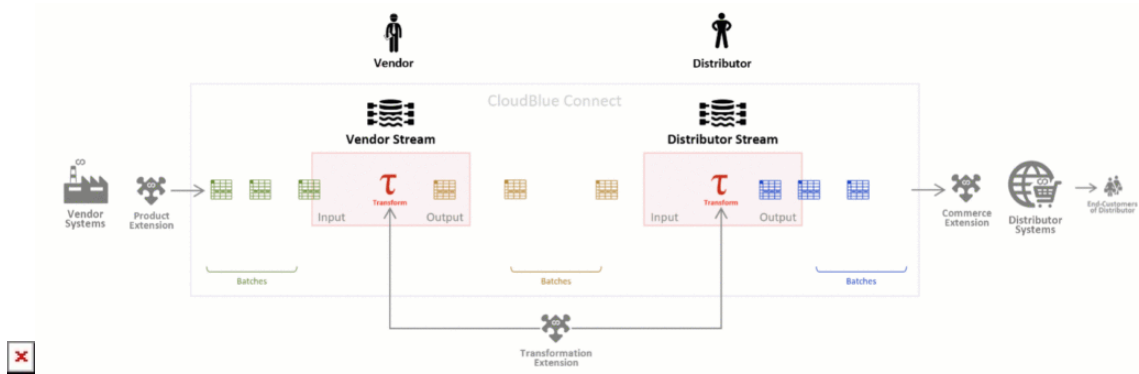

The Commerce module collects data provided by an external system via an extension. This module also allows using extensions to initiate the transformation of required data and to organize the transition of the transformed data to business partners.

For example, Vendor systems can generate initial billing information and use a product extension to submit this data to *Vendor Streams* on the Connect platform. Consequently, this billing data is shared with Distributors, which in turn can use their own logic to generate billing information for end-customers and Resellers. The provided and shared billing data is organized via specific objects that are called *Billing Batches*. Pricing and other data streams follow the same pattern for transitioning required information throughout the supply chain.

## End-to-End Scenario

Data stream management provides flexibility for different business scenarios and operations. Therefore, the CloudBlue Connect platform features comprehensive functionality for any billing, pricing, and other data stream transitions regardless of the complexity of your supply chain.

The following outlines the most complex end-to-end business scenario for Vendors, Distributors, and Resellers on Connect:

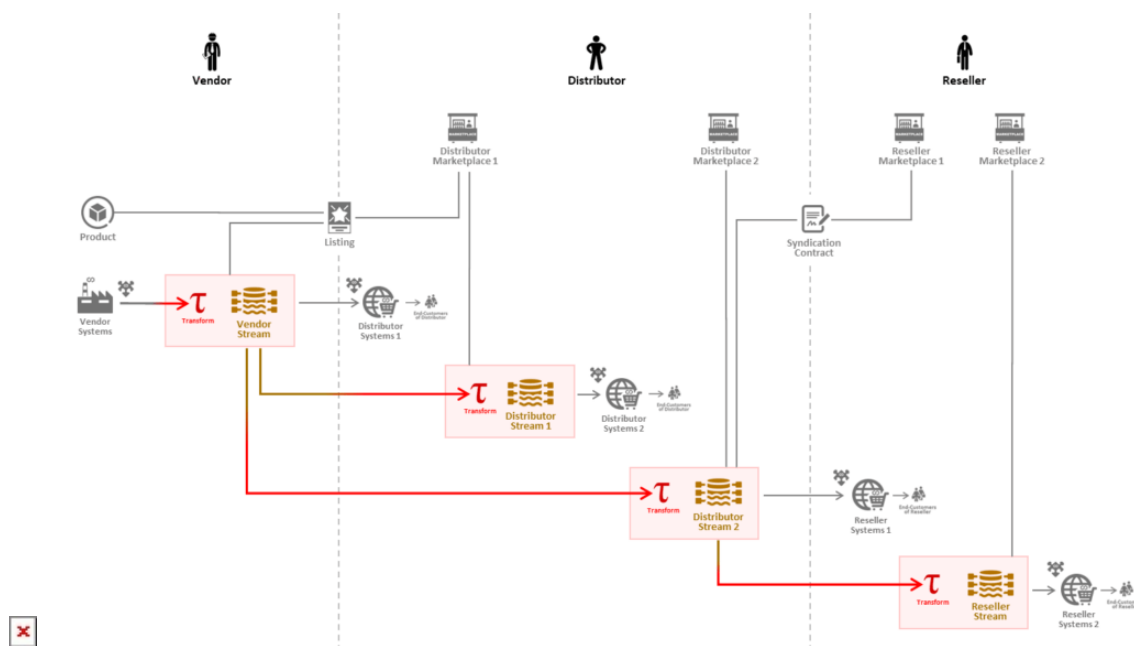

First of all, Vendors establish a data stream that includes generated billing batches, price lists, or any other data depending on the operation. Vendors define a data stream in a scope of particular product and listing. All data streams stay in the *Private* mode until they are explicitly shared with Distributors.

Subsequently, Distributors can use information that is provided via *Vendor Streams* for the following scenarios:

- Distributors can submit provided data directly to their system and then share it with end-customers.
- The system allows Distributors to *transform* acquired information and organize *Distributor Streams* to pass modified data to end-customers.
- Distributors can also transform acquired data to establish *Distributor Streams* in a scope of specific *Syndication Contract*. Therefore, this scenario allows transferring modified information to Resellers.

The Commerce module enables Resellers to perform similar business operations. Namely, Resellers can submit the data that is provided via *Distributor Streams* directly to their system. Alternatively, Resellers can transform the provided information and organize their own *Reseller Streams* to pass their modified data to end-customers.

## Data Streams and Their Types

Data streams define transformation of both input and output data in a specific business context. For instance, billing streams represent business flows that allow managing the creation billing batches and the transition of such batches from Vendors to Distributors, from Distributors to Resellers or customers, and so on.

The system allows creating *simple* streams and also *chaining* data streams as illustrated and described below:

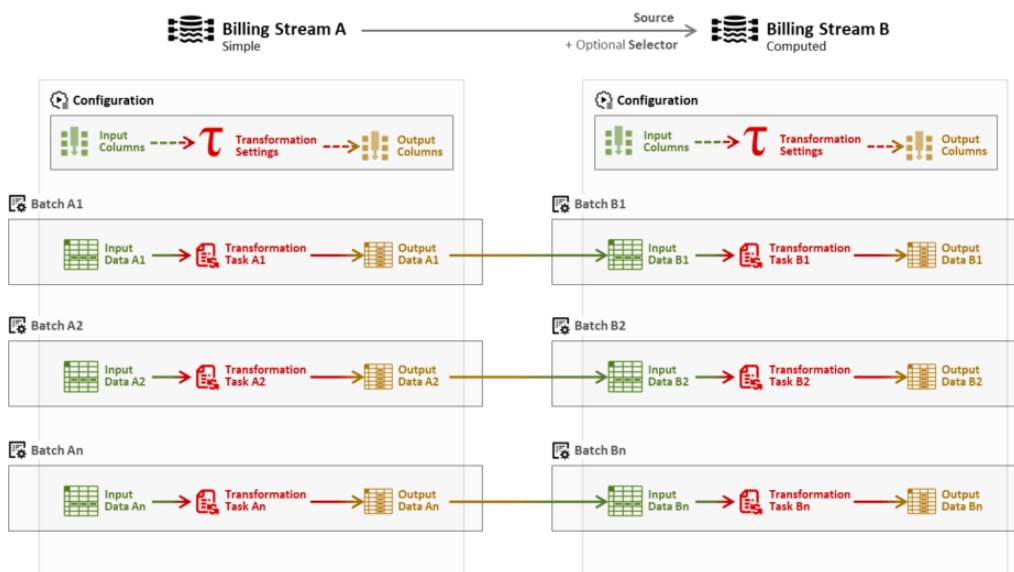

- **Simple** streams represent independent objects that don't include any references to existing streams in the systems. Such streams incorporate input data that is provided by external systems. These streams are typically generated by Vendors to transfer required billing batches to their business partners.
- **Computed** streams, on the other hand, use existing streams as a source to define data required for subsequent operations. Specifically, the output information of other streams serves as the input data of computed streams that is consequently transformed to meet specific business requirements. Computed streams are increasingly useful for Distributors and Resellers that use generated streams for their subsequent operations.
  - Computed streams might also incorporate a **Selector** to get a subset of data by using a given criteria. Therefore, this allows filtering out unwanted data and include only data rows that refer to a specific organization, customer, etc.

The Commerce module also features a comprehensive functionality that allow configuring transformations of table-based data within any billing stream. Thus, it is important to learn more about transformation processes and essential configuration options.

## Data Stream Transformations

The transformations of required data (e.g., billing information) are defined as pieces of a business logic that use certain columns within spreadsheet tables as *input* and certain columns as *output*. Meaning that the system allows performing multiple transformation operations that help generate new output columns within your spreadsheet. Therefore, your generated output columns can also serve as an input for subsequent transformation procedures.

The following showcases several transformation operations for billing stream and highlights critical constraints for billing stream configuration:

### Billing Stream Configuration

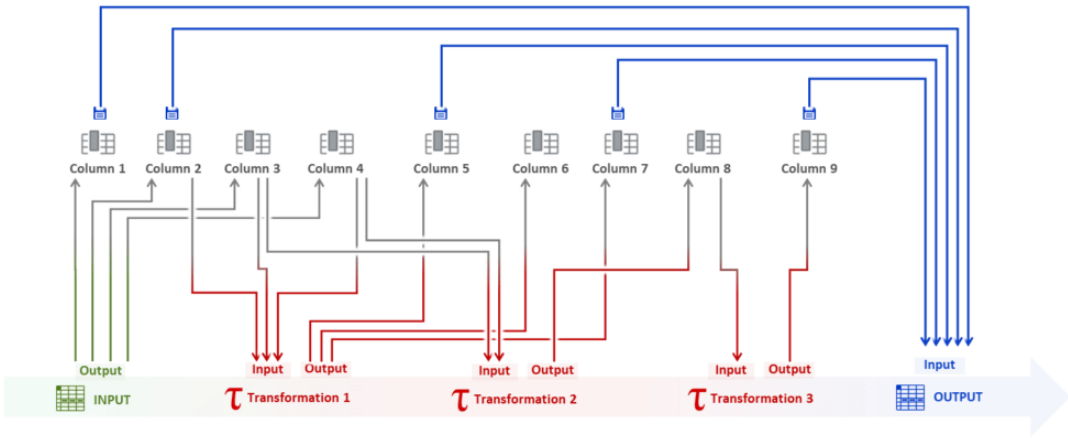

### Each Column has unique (single) origin

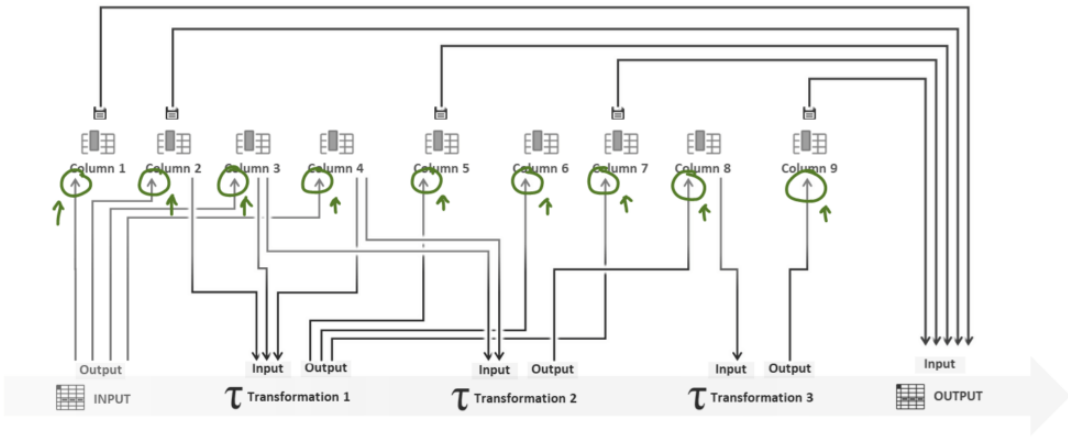

### Each Column can be used for multiple transformations

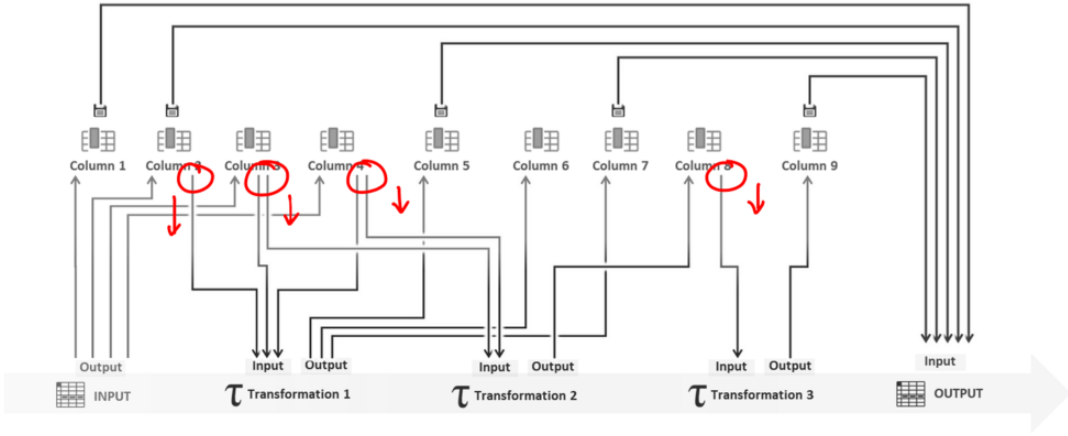

### Choose which columns should be stored in the output

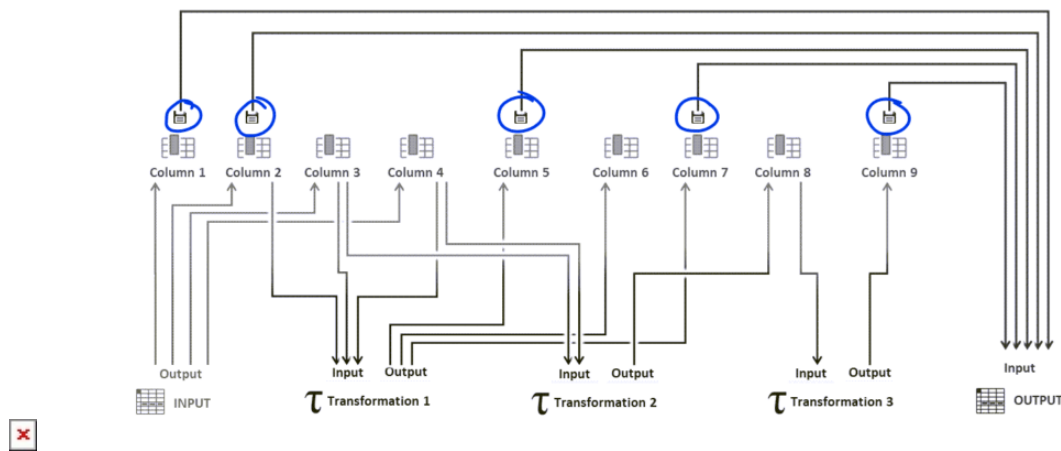

In general, organizations execute multiple transformations of billing data to meet all business requirements and transfer generated batches to their business partner. The diagram above demonstrates initiated transformation operations that work with provided *input* data or with *output* data from previous transformation procedures. The system also allows performing one transformation or skipping such operations completely if necessary.

Furthermore, the diagram above outlines the following constraints:

- Each column can only have a single (*unique*) origin.
- Each column can be used for multiple transformations.
- The system allows selecting columns that will be stored in the output file.

Note that the system provides a number of configurations that can be applied for your transformation procedures and that can simplify various operations, such as lookups for subscription data, product item data, currency converter, and so on. The detailed description of available configuration options is presented in the User Interface article.